

GERÄTE KATALOG



MIETEN STATT KAUFEN

WILLKOMMEN ZU UNSEREM GERÄTE KATALOG



Kommen Sie zu uns, wo die Auswahl grenzenlos, die Ideen bahnbrechend, der Service menschlich und die Preise bezahlbar sind.

JOSEF FRANKL
CEO Frankl24 GmbH



**In unserer digitalen Ausgabe des
FRANKL24 Geräte Katalogs bringen
wir sie direkt zu Ihrem gewünschten Produkt.
Viel Spaß beim Draufklicken.**



KATEGORIEN

4 KOMBIDÄMPFER
& ÖFEN

12 KOCHSTELLEN
& HERDE

18 FRITUSEN
KIPPER & KESSEL

24 MICROWELLEN,
INDUKTIONEN, NIEDER-
TEMPERATURGAREN
& PASTAKOCHER

30 DIVERSE
KÜCHENGERÄTE

34 EVENT
& LIFESTYLEGERÄTE

42 KAFFEE, TEE
HEISSGETRÄNKE

48 WÄRME & WARM-
HALTEGERÄTE

56 GRILLS

66 SPÜLTECHNIK

80 GERÄTEZUBEHÖR

THEMENWELTEN

82 ASIEN

86 AMERIKA

92 MEDITERRAN-VEGGI

98 BAR, BIERZELT,
HEURIGEN &
GARTENPARTY

104 STROM
ZU & ABWASSER,
HEIZUNG & KÜHLEN

112 TRANSPORT-
LOGISTIK

EINE KLASSE FÜR SICH



KOMBIDÄMPFER & ÖFEN



KOMBIDÄMPFER "RETIGO" 20 GN 1/1

Power: 400 V 63 A, CEE
Maße: H 1,95 m B 1,02 m T 0,85 m



KOMBIDÄMPFER "RETIGO" 14 GN 1/1

Power: 400 V, 16 A, CEE
Maße: H 1,90 m B 1,10 m T 0,90 m



KOMBIDÄMPFER "RETIGO" 7 GN 1/1

Power: 400 V, 16 A, CEE
Maße: H 1,90 m B 1,10 m T 0,90 m



KOMBIDÄMPFER "RETIGO" 7 GN 1/1

Power: 230 V & Propangas
Maße: H 1,90 m B 1,10 m T 0,90 m



KOMBIDÄMPFER 6 GN 1/1

Power: 400 V, 16 A, CEE
Maße: verschiedene Modelle



KOMBIDÄMPFER 10 GN 1/1

Power: 400 V, 32 A, CEE
Maße: verschiedene Modelle



KOMBIDÄMPFER 6 GN 1/1 MIT UNTERBAU

Power: 400 V, 16 A, CEE
Maße: verschiedene Modelle

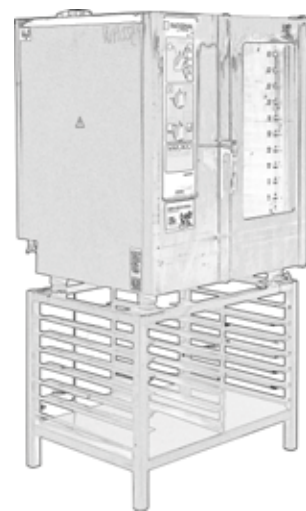

KOMBIDÄMPFER 10 GN 1/1 MIT UNTERGESTELL

Power: 400 V, 32 A, CEE
Maße: verschiedene Modelle



KOMBIDÄMPFER 20 GN 1/1

Power: 400 V, 63 A, CEE
Maße: H 2 m B 1 m T 0,85 m



KOMBIDÄMPFER 40 GN 1/1

Power: 400 V, 125 A, CEE
Maße: H 2 m B 1,35 m T 1,06 m

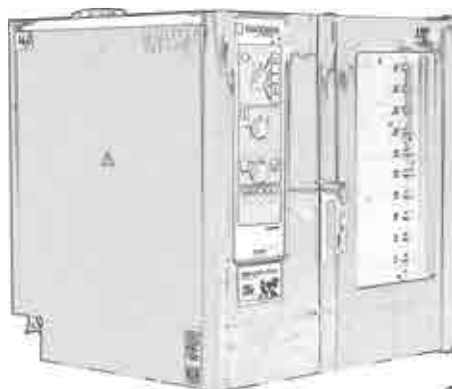

KOMBIDÄMPFER 10 GN 2/1

Power: 400 V, 63 A, CEE
Maße: verschiedene Modelle



HEISLUFTOFEN "MMH" 4 GN 1/2 GN

Power: 230 V
Maße: verschiedene Modelle



HEISLUFTOFEN "APEXA" 4 EINSCHÜBE

Power: 230 V
Maße: H 0,35 m B 0,50 m T 0,50 m
Bleche mit Sondermassen



HEISLUFTOFEN "BARTSCHER" 4 GN 1/1

Power: 400 V, 16 A, CEE
Maße: H 0,60 m B 0,75 m T 0,85 m



HEISLUFTOFEN "BARTSCHER" 6 GN 1/1

Power: 400 V, 16 A, CEE
Maße: H 0,80 m B 0,95 m T 0,70 m



HEISLUFTOFEN 6 GN 1/1

Power: 400 V, 16 A, CEE
Maße: verschiedene Modelle



HEISLUFTOFEN 10 GN 1/1

Power: 400 V, 32 A, CEE
Maße: verschiedene Modelle

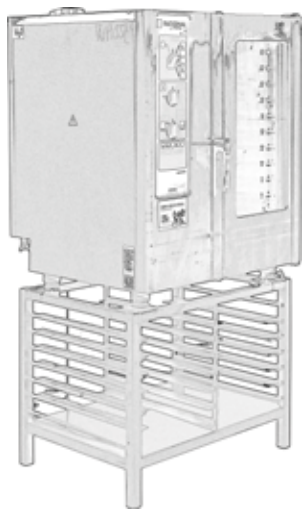

KOMBIDÄMPFER "RATIONAL" 10 GN 1/1 GAS

Power: 230 V & Propangas

Maße: H 1,80 m B 0,90 m T 0,80 m



KOMBIDÄMPFER 20 GN 1/1 GAS

Power: 400 V, 16 A, CEE & Propangas

Maße: H 2 m B 1 m T 0,85 m

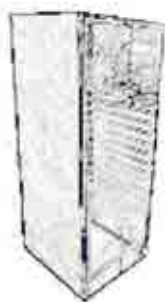

ABDECKHAUBE FÜR
HORDENGESTELLWAGEN
20 GN 1/1



EINSCHUBWAGEN
FÜR 201



EINSCHUBWAGEN
FÜR 202

**PIZZAOFEN KLEIN 1 - STÖCKIG**

Power: 230 V
Maße: H 0,35 m B 0,75 m T 0,75 m

**PIZZAOFEN KLEIN 1 - STÖCKIG**

Power: 230 V
Maße: H 0,35 m B 0,75 m T 0,75 m

**PIZZAOFEN MITTEL 1 - STÖCKIG**

Power: 400 V, 16 A, CEE
Maße: H 0,45 m B 0,95 m T 0,85 m

**PIZZAOFEN GROSS 1 - STÖCKIG**

Power: 400 V, 16 A, CEE
Maße: verschiedene Modelle

**PIZZAOFEN GROSS 2 - STÖCKIG**

Power: 400 V, 16 A, CEE
Maße: verschiedene Modelle

**PIZZADURCHLAUFOFEN**

Power: 400 V, 16 A, CEE
Maße: H 0,40 m B 1,30 m T 0,80 m

**PIZZASCHAUFEL**

Maße: verschiedene Modelle

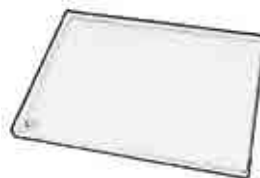
**PIZZABLECH ECKIG**

Maße: B 0,50 m L 0,50 m

**PIZZABLECH RUND**

Maße: Ø 0,50 m

WEM ES AM
HERD ZU
HEISS IST,

DER HAT IN

DER KÜCHE

NICHTS

VERLOREN



KOCHSTELLEN & HERDE



KOCHPLATTE 1-FACH CERAN

Power: 230 V
Maße: H 0,15 m Ø 0,36 m



KOCHPLATTE 2-FACH

Power: 400 V, 16 A, CEE
Maße: H 0,32 m B 0,40 m T 0,62 m



KOCHPLATTE 4-FACH

Power: 400 V, 16 A, CEE
Maße: verschiedene Modelle



HOCKERKOCHER

Power: 230 V
Maße: H 0,40 m B 0,40 m T 0,50 m



AUFTISCHKOCHER

Power: 400 V, 16 A, CEE
Maße: H 0,25 m B 0,55 m T 0,55 m



HOCKERKOCHER

Power: 400 V, 16 A, CEE
Maße: verschiedene Modelle



KOCHPLATTEN CERAN

Power: 400 V 16 A, CEE
Maße: H 0,35 m B 0,60 m T 0,65 m



K-POT

Power: 400 V, 16 A, CEE
Maße: H 0,08 m B 0,35 m T 0,40 m

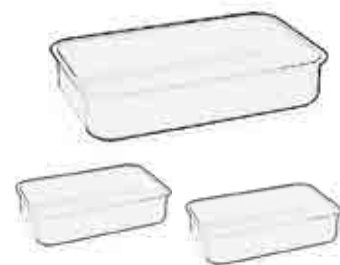

DIVERSES ZUBEHÖR K-POT



ELEKTROHERD 4 PLATTEN

Power: 400 V, 16 A, CEE
Maße: verschiedene Modelle



ELEKTROHERD 4 PLATTEN

Power: 400 V, 16 A, CEE oder 32 A, CEE
Maße: verschiedene Modelle

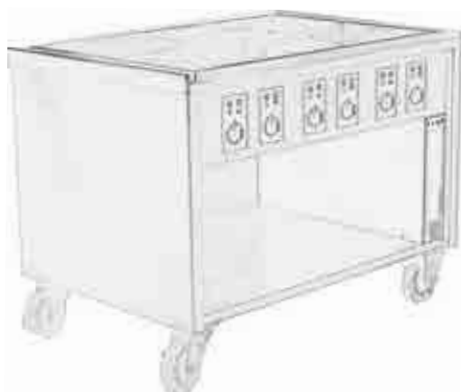

ELEKTROHERD 6 PLATTEN CERAN

Power: 400 V, 32 A, CEE
Maße: verschiedene Modelle



ELEKTROHERD 8 PLATTEN

Power: 400 V, 63 A, CEE
Maße: H 0,95 m B 1,60 m T 0,95 m



TISCHKOCHER GAS DOPPELT

Power: Propangas
Maße: verschiedene Modelle



TISCHKOCHER GAS DOPPELT WOK

Power: Propangas
Maße: verschiedene Modelle



WOKAUFSATZ

Maße: H 1,55 m B 0,75 m T 0,65 m



HOCKERKOCHER GAS KLEIN

Power: Propangas
Maße: H 0,40 m B 0,40 m T 0,40 m



HOCKERKOCHER GAS MITTEL

Power: Propangas
Maße: H 0,60 m B 0,40 m T 0,40 m



HOCKERKOCHER GAS GROSS

Power: Propangas
Maße: H 0,75 m B 0,75 m T 0,75 m



HK GAS FÜR RIESENPFANNE

Power: Propangas
Maße: H 0,75 m B 0,75 m T 0,75 m



HOCKERKOCHER GAS GROSS

Power: Propangas
Maße: H 0,85 m B 0,65 m T 0,65 m

WORKING
CLASS
HEROES



**FRITEUSEN, KIPPER
& KESSEL**





EINBECKENFRITEUSE KLEIN

Power: 230 V
 Maße: 5 - 8 Liter Volumen
 verschiedene Modelle



EINBECKENFRITEUSE MITTEL

Power: 2 x 230 V oder 16 A, CEE
 Maße: 8 - 10 Liter Volumen
 verschiedene Modelle



EINBECKENFRITEUSE GROSS

Power: 400 V, 16 A, CEE
 Maße: 10 - 12 Liter Volumen
 verschiedene Modelle

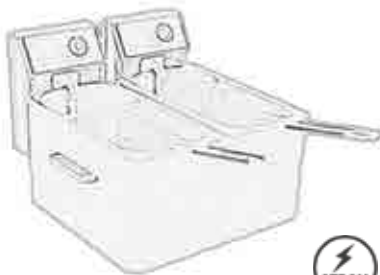

DOPPELFRITEUSE KLEIN

Power: 2 x 230 V
 Maße: 5 - 8 Liter Volumen pro
 Becken, versch. Modelle

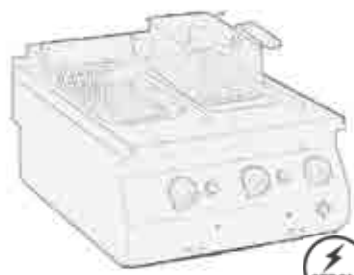

DOPPELFRITEUSE MITTEL

Power: 2 x 16 A, CEE
 oder 32A, CEE
 Maße: 8 - 10 Liter Volumen pro
 Becken, versch. Modelle



DOPPELFRITEUSE GROSS

Power: 400 V, 32 A, CEE
 Maße: 10 - 12,5 Liter Volumen pro
 Becken, versch. Modelle



FETTBACKGERÄT

Power: 400 V, 16 A, CEE
 Maße: 25 Liter Volumen



STANDFRITEUSE EINBECKEN

Power: 400 V, 32 A, CEE
 Maße: 12,5 Liter Volumen
 H 0,9 m B 0,5 m T 0,9 m



KIPPBRATPFANNE

Power: 230 V & Propangas
 Maße: 70 Liter Volumen
 H 0,85 m B 1,60 m T 0,85 m



KOCHKESSEL

Power: 400 V, 16 A, CEE
Maße: 50 Liter Volumen
H 1,95 m B 1,02 m T 0,85 m



KOCHKESSEL

Power: 400 V, 32 A, CEE
Maße: 70 Liter Volumen
H 0,90 m B 1,20 m T 0,90 m

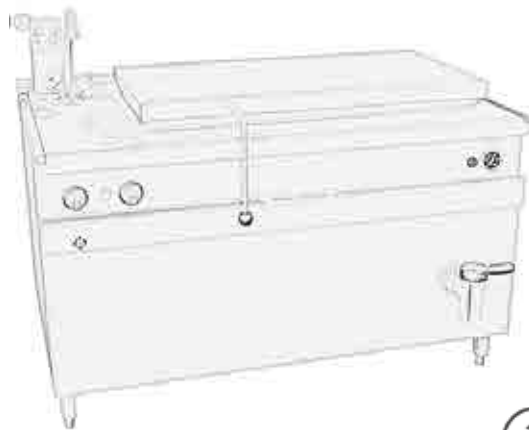

KOCHKESSEL

Power: 400 V, 63 A, CEE
Maße: 200 Liter Volumen
H 0,85 m B 1,25 m T 0,90 m



KIPPBRATPFANNE

Power: 400 V, 16 A, CEE
 Maße: 30 - 50 Liter Volumen
 verschiedene Modelle



KIPPBRATPFANNE

Power: 400 V, 32 A, CEE
 Maße: 50 - 70 Liter Volumen
 verschiedene Modelle



KIPPBRATPFANNE

Power: 400 V, 32 A, CEE
 Maße: 90 Liter Volumen
 H 0,95 m B 1,25 m T 1,05 m



KIPPBRATPFANNE

Power: 400 V, 32 A, CEE
 Maße: 120 Liter Volumen
 H 1,00 m B 1,20 m T 0,90 m

VORSPIRUNG

DURCH

TECHNIK



**MIKROWELLE, INDUKTION,
NIEDER-TEMPERATURGAREN
& PASTAKOCHER**



MIKROWELLE GASTRO

Power: 230 V
Maße: verschiedene Modelle



MIKROWELLE GASTRO GROSS

Power: 230 V
Maße: H 0,50 m B 0,65 m T 0,55 m



INDUKTIONSWOK

Power: 230 V
Maße: H 0,20 m B 0,40 m T 0,50 m



INDUKTIONSKOCHFELD

Power: 230 V
Maße: H 0,35 m B 0,40 m T 0,45 m



WOKEINSATZ FÜR INDUKTIONSKOCHFELD

Maße: H 1,55 m B 0,75 m T 0,65 m



INDUKTIONSPFANNE GROSS



INDUKTIONSWOKPFANNE



INDUKTIONSWOKPFANNE FLACHER BODEN



DIVERSE TÖPFE INDUKTIONSFÄHIG



NIEDERTEMPERATUROFEN 3 GN 1/1

Power: 230 V

Maße: H 0,45 m B 0,50 m T 0,70 m



NIEDERTEMPERATUROFEN 6 GN 1/1

Power: 230 V

Maße: H 0,60 m B 0,40 m T 0,65 m



WÄRMEWAGEN

Power: verschiedene Modelle

Maße: verschiedene Modelle



ALTO SHAAM MIT GLASTÜRE

Power: 230 V

Maße: verschiedene Modelle



SOUS VIDE GARER

Power: 230 V

Maße: verschiedene Modelle



SOUS VIDE GARER

Power: 230 V

Maße: verschiedene Modelle



PASTAKOCHER TISCHGERÄT

Power: 400 V, 16 A, CEE
Maße: verschiedene Modelle

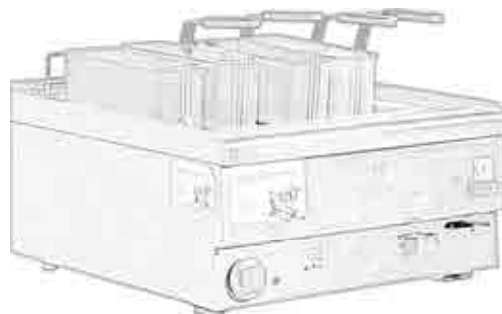

PASTAKOCHER TISCHGERÄT INKL. 4 EINSÄTZE

Power: 400 V, 16 A, CEE
Maße: verschiedene Modelle



PASTAKOCHER STANDGERÄT INKL. 2 EINSÄTZE

Power: 400 V, 16 A, CEE
Maße: H 0,95 m B 0,35 m T 0,75 m



PASTAKOCHER STANDGERÄT INKL. 4 EINSÄTZE

Power: 400 V, 16 A, CEE
Maße: H 0,95 m B 0,50 m T 0,75 m



Kitchen
POSSIBLE



DIVERSE KÜCHENGERÄTE



PACOJET INCL. 4 BECHER

Power: 230 V

Maße: H 0,50 m B 0,20 m T 0,40 m



ZUSATZBECHER FÜR PACOJET MIT DECKEL



THERMOMIX TM 5

Power: 230 V

Maße: H 0,35 m B 0,35 m T 0,35 m



BARMIXER

Power: 230 V

Maße: verschiedene Modelle



PÜRIERSTAB

Power: 230 V

Maße: verschiedene Modelle



STABMIXER "PROFI"

Power: 230 V

Maße: verschiedene Modelle



AUFSCHNITTMASCHINE

Power: 230 V

Maße: verschiedene Modelle



AUFSCHNITTMASCHINE "BERKEL"

Power: 230 V

Maße: verschiedene Modelle



DIGITALE KÜCHENWAGE

Power: 230 V

Maße: verschiedene Modelle

**SALAMANDER**

Power: 230 V
Maße: H 0,35 m B 0,80 m T 0,55 m

**SALAMANDER**

Power: 400 V, 16 A, CEE
Maße: H 0,50 m B 0,85 m T 45 m

**VAKUMIERMASCHINE**

Power: 400 V, 16 A, CEE
Maße: H 0,95 m B 0,50 m T 0,70 m

**ALEXANDERWERK FAHRBAR**

Power: 400 V, 16 A, CEE
Maße: H 1,40 m B 0,75 m T 1,00 m

**ALEXANDERWERK JUMBO**

Power: 400 V, 16 A, CEE
Maße: H 0,32 m B 0,40 m T 0,62 m

**TEIGNETMASCHINE**

Power: 400 V, 16 A, CEE
Maße: verschiedene Modelle

**SPEIETRANSPORTBAND**

Power: 400 V, 16 A, CEE
Maße: L 3,20 m H 0,90 m T 0,60 m

**SPEIETRANSPORTBAND**

Power: 230 V
Maße: L 6,00 m H 0,90 m T 0,60 m

**DUNSTABZUGSHAUBE**

Power: 230 V
Maße: H 0,80 m B 2,6 m T 1,0 m

SIE

WÜNSCHEN

WIR

SPIELEN



**EVENT &
LIFESTYLE GERÄTE**



SCHOKOLADENBRUNNEN 33 CM

Power: 230 V
Maße: verschiedene Modelle



SCHOKOLADENBRUNNEN 64 CM

Power: 230 V
Maße: verschiedene Modelle



SCHOKOLADENBRUNNEN 102 CM

Power: 230 V
Maße: verschiedene Modelle



ZUCKERWATTEMASCHINE

Power: 230 V
Maße: verschiedene Modelle



ZUCKERWATTEMASCHINE MIT WAGEN

Power: 230 V
Maße: H 1,00 m B 0,80 m T 0,80 m



MINIDONUTMASCHINE

Power: 230 V
Maße: H 0,40 m B 0,90 m T 0,60 m



POPCORNMASCHINE KLEIN

Power: 230 V
Maße: verschiedene Modelle
15 Liter in 1 Std.



POPCORNMASCHINE MITTEL

Power: 230 V
Maße: verschiedene Modelle
15 Liter in 1 Std.



POPCORNMASCHINE GROSS

Power: 230 V
Maße: verschiedene Modelle
15 Liter in 1 Std.



DAMPFNUDELWÄRMER

Power: 230 V
Maße: H 0,60 m B 0,35 m T 0,50 m



WAFFELEISEN EINFACH

Power: 230 V
Maße: verschiedene Modelle



WAFFELEISEN DOPPELT

Power: 2 x 230 V
Maße: verschiedene Modelle



MULTIPFANNE

Power: 230 V
Maße: H 0,60 m Ø 0,50 m



CREPESGERÄT EINFACH

Power: 230 V
Maße: H 0,40 m B 0,90 m T 0,60 m



CREPESGERÄT DOPPELT

Power: 2 x 230 V o. 16 A, CEE
Maße: verschiedene Modelle



SAHNEBEREITER

Power: 230 V
Maße: H 0,65 m B 0,35 m T 0,65 m



CREPESGERÄT EINFACH GAS

Power: Propangas
Maße: verschiedene Modelle



CREPESGERÄT DOPPELT GAS

Power: Propangas
Maße: verschiedene Modelle

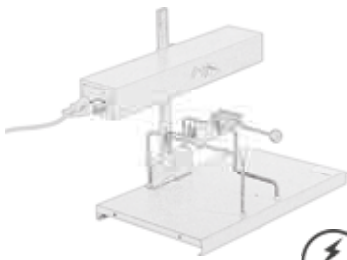

RACLETTEOFEN

Power: 230 V
Maße: verschiedene Modelle

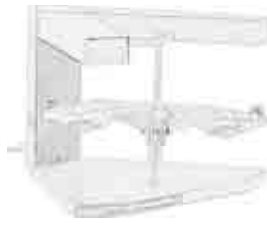

RACLETTEOFEN GROSS

Power: 230 V
Maße: verschiedene Modelle
für 3 Laibe



FOUNDUETOPF MIT UNTERGESTELL

Power: Brennpaste
Maße: H 0,20 m Ø 20 cm



GYROSGRILL GAS

Power: 230 V & Propangas
Maße: H 1,10 m B 0,50 m T 0,50 m



GYROSGRILL KLEIN

Power: 230 V
Maße: H 1,10 m B 0,50 m T 0,50 m



GYROSGRILL

Power: 400 V, 16 A, CEE
Maße: H 1,15 m B 1,00 m T 0,55 m



KARTOFFELOFEN

Power: 230 V
Maße: H 0,95 m B 0,60 m T 0,75 m
ca. 150 Kartoffel + warmhalten



FLAMMBROTOFEN GAS/HOLZKOHLE

Power: Propangas oder Holzkohle
Maße: H 1,00 m B 1,20 m T 1,55 m



PROFIDURCHLAUFTOASTER

Power: 230 V
Maße: H 0,35 m B 0,40 m T 0,45 m



HOT DOG-BROTSPIESS

Power: 230 V

Maße: verschiedene Modelle



HOT DOG-WÜRSTCHENWÄRMER

Power: 230 V

Maße: verschiedene Modelle



HOT DOG - ROLLGRILL

Power: 230 V

Maße: H 0,20 m B 0,60 m T 0,40 m



CURRYWURSTSCHNEIDER

Power: 230 V

Maße: H 0,40 m B 0,20 m T 0,25 m

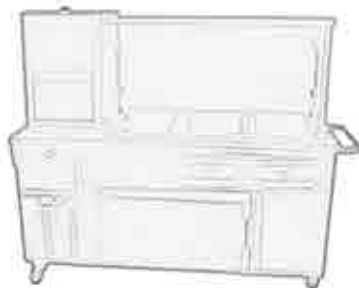

HOT DOG STAND

Power: 400 V, 16 A, CEE

Maße: H 1,45 m B 1,60 m T 0,70 m



HOT DOG WAGEN

Power: 230 V & Propangas

Maße: H 1,60 m B 1,20 m T 1,80 m



SAMOWAR KLEIN

Power: 230 V
Maße: 1,5 Liter Volumen
verschiedene Modelle



SAMOWAR MITTEL

Power: 230 V
Maße: 3 Liter Volumen
verschiedene Modelle



SAMOWAR GROSS

Power: 230 V
Maße: 15 Liter Volumen
verschiedene Modelle



BARMIXER

Power: 230 V
Maße: verschiedene Modelle



ENTSAFTER

Power: 230 V
Maße: verschiedene Modelle



FROZEN MARGARITA MASCHINE

Power: 230 V
Maße: 12 L Volumen pro Behälter



ZITRUSPRESSE MIT HEBEL

Maße: verschiedene Modelle



ENTSAFTER

Power: 230 V
Maße: H 0,45 m B 0,30 m T 0,40 m



ORANGENPRESSE "ZUMEX"

Power: 230 V
Maße: H 1,75 m B 0,70 m T 0,70 m

**RIESENPFANNE**

Maße: verschiedene Modelle

**RIESENPFANNE GETEILT**

Maße: verschiedene Modelle

**RIESENWOK**

Maße: verschiedene Modelle

**MARONIOFEN ELEKTRO**Power: 400 V, 16 A, CEE
Maße: H 0,90 m Ø 0,60 m**MARONIOFEN GAS**Power: Propangas
Maße: H 0,90 m Ø 0,60 m**MARONIOFEN HOLZKOHLE**Power: Holzkohle
Maße: H 0,90 m Ø 0,60 m**DREIBEIN MIT EDELSTAHLKESSEL**

Maße: verschiedene Modelle

**DREIBEIN MIT SCHWENKROST**

Maße: verschiedene Modelle

**FEUERSCHALE O. FEUERKORB**

Maße: verschiedene Modelle

Kaffee

erreicht Stellen,

da kommt

MOTIVATION

nicht hin



KAFFEE, TEE & HEISSGETRÄNKE



ESPRESSOMASCHINE "FAEMA DUE" 1-GRUPPIG

Power: 230 V
& Festwasseranschluss
Maße: H 0,55 m B 0,50 m T 0,60 m



ESPRESSOMASCHINE "GAGIA" 2-GRUPPIG

Power: 230 V
& Festwasseranschluss
Maße: H 0,60 m B 0,65 m T 0,55 m



ESPRESSOMASCHINE "FAEMA" 3-GRUPPIG

Power: 400 V, 16A, CEE
& Festwasseranschluss
Maße: H 0,55 m B 1,0 m T 0,60 m



ESPRESSO, - KAFFEEBOHNENMÜHLE

Power: 230 V
Maße: verschiedene Modelle



WASSERKOCHER

Power: 230 V
Maße: verschiedene Modelle



ESPRESSOMASCHINE "BELLE EPOQUE" 2-GRUPPIG

Power: 230 V & Festwasseranschluss
Maße: H 1,15 m B 0,70 m T 0,70 m



KAPSELMASCHINEN "NESPRESSO"

Power: 230 V
Maße: verschiedene Modelle



KAPSELMASCHINE "NESPRESSO" 2-GRUPPIG MIT MILCHSCHÄUMER

Power: 230 V
Maße: verschiedene Modelle



MILCHSCHÄUMER

Power: 230 V
Maße: 0,5 Liter Volumen, H 0,25 m Ø 0,20 m



ESPRESSOMASCHINE "DELONGHI MAGNIFICA"

Power: 230 V
Maße: verschiedene Modelle



KAFFEEVOLLAUTOMAT "LA CIMBALI Q 10"

Power: 230 V
Maße: H 0,90 m B 0,35 m T 0,80 m
auch autarkes System möglich



KAFFEEVOLLAUTOMAT "LA CIMBALI Q 10" ROLLCASE

Power: 230 V
Maße: H 1,50 m B 1,00 m T 0,90 m
auch autarkes System möglich



RUNDFLITERKAFFEEMASCHINE

Power: 230 V
Maße: 9 -14 Liter Volumen
verschiedene Modelle



FILTERKAFFEEMASCHINE + 2 KANNEN

Power: 230 V
Maße: H 0,55 m B 0,30 m T 0,40m

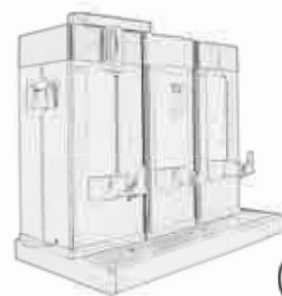

KAFFEEGROSSBRÜHANLAGE 2 X 8 L

Power: 400 V, 16 A, CEE
& Festwasseranschluss
Maße: 2 x 8 Liter Volumen
H 0,85 m B 0,85 m T 0,30 m



KAFFEEGROSSBRÜHANLAGE 2 X 10 L

Power: 400 V, 16 A, CEE
& Festwasseranschluss
Maße: 2 x 10 Liter Volumen
H 0,85 m B 0,85 m T 0,40 m



KAFFEEGROSSBRÜHANLAGE 2 X 40 L

Power: 400 V, 16 A, CEE
& Festwasseranschluss
Maße: 2 x 40 Liter Volumen
H 1,15 m B 1,20 m T 0,50 m



KAFFEEGROSSBRÜHANLAGE 2 X 70 L

Power: 400 V, 16 A CEE
& Festwasseranschluss
Maße: 2 x 70 Liter Volumen
H 0,85 m B 0,85 m T 0,30 m



SAMOWAR 1,5 - 15 L

Power: 230 V
Maße: verschiedene Modelle



GLÜHWEINKOCHER

Power: 230 V
Maße: verschiedene Modelle



GLÜHWEINDURCHLAUFERHITZER

Power: 400 V, 16 A, CEE
Maße: H 0,35 m B 0,40 m T 0,60 m



HEISS

MUSS ES

JEDEM

RECHT SEIN,

KALT

WIRD'S

VON SELBER



WÄRME & WARMHALTEGERÄTE



BAIN MARIE FAHRBAR 2 GN 1/1

Power: 230 V
Maße: verschiedene Modelle



BAIN MARIE FAHRBAR 3 GN 1/1

Power: 230 V
Maße: verschiedene Modelle



WARMAUSGABE 3 GN 1/1

Power: 400 V, 16 A, CEE
Maße: H 1,55 m B 1,20 m T 0,75 m



BAIN MARIE AUFTISCH 1 GN 1/1

Power: 230 V
Maße: H 0,35 m B 0,40 m T 0,70 m



BAIN MARIE AUFTISCH 1 GN 2/1

Power: 230 V
Maße: H 0,35 m B 0,80 m T 0,70 m



WÄRMESCHRANK UNTERTISCH

Power: 230 V
Maße: H 0,90 m B 0,75 m T 0,50 m



TELLERWÄRMER OFFEN

Power: 230 V
Maße: verschiedene Modelle



TELLERWÄRMER 2 STAPEL

Power: 230 V
Maße: verschiedene Modelle



LEBERKÄSWARMHALTEOFEN

Power: 230 V
Maße: H 0,5 m B 0,60 m T 0,30 m



WÜRSTCHENWÄRMER 2 BECKEN

Power: 230 V
Maße: 5 Liter Volumen pro Becken
H 0,30 m B 0,75 m T 0,30 m



WARMHALTEGERÄT FÜR POMMES

Power: 230 V
Maße: H 0,60 m B 1,10 m T 0,80 m



HEISSE THEKE 1 GN 1/1

Power: 230 V
Maße: H 0,65 m B 0,70 m T 0,45 m



HEISSE THEKE 2 GN 1/1

Power: 230 V
Maße: H 0,65 m B 0,85 m T 0,70 m



HEISSE THEKE 3 GN 1/1

Power: 230 V
Maße: H 0,60 m B 1,10 m T 0,80 m



TISCHRECHAUD 5-12 PLATTEN

Power: 230 V
Maße: verschiedene Modelle



ALTO SHAAM SCHNEIDEBRETT

Power: 230 V
Maße: H 0,55 m B 0,65 m T 0,80 m



WÄRMEWAGEN UMLUFT

Power: 230 V
Maße: verschiedene Modelle



WÄRMEWAGEN BODENHEIZUNG

Power: 230 V
Maße: verschiedene Modelle



WÄRMEWAGEN HECKHEIZUNG

Power: 230 V
Maße: verschiedene Modelle



WÄRMEWAGEN THERMOSTATGESTEUERT

Power: 230 V
Maße: verschiedene Modelle





CHAFING DISH

Maße: H 0,35 m B 0,60 m T 0,40 m



CHAFING DISH ROLLTOP

Maße: H 0,35 m B 0,60 m T 0,40 m



SUPPEN CHAFING DISH

Maße: H 0,35 m B 0,60 m T 0,40 m



THEKENKESSEL

Power: 230 V
Maße: H 0,40 m Ø 0,40 m
10 Liter Volumen



SUPPENSTATION 2 ODER 4 FACH

Power: 230 V
Maße: verschiedene Modelle



CHAFING DISH HEIZUNG

Power: 230 V
Maße: verschiedene Modelle



WÄRMELAMPE

Power: 230 V
Maße: verschiedene Modelle



ALTO SHAAM SCHNEIDBRETT

Power: 230 V
Maße: H 0,55 m B 0,65 m T 0,80 m



WÄRMEBRÜCKE 1,20 - 1,70 M

Power: 230 V
Maße: verschiedene Modelle



THERMOBOX 1/1 GN

Maße: H 0,30 m B 0,65 m T 0,40 m

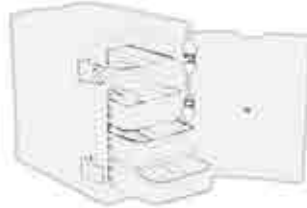

THERMOBOX 6 GN 1/1

Maße: H 0,45 m B 0,45 m T 0,20 m

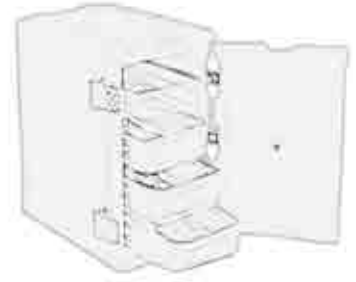

THERMOBOX 12 GN 1/1

Maße: H 0,45 m B 0,45 m T 0,20 m



THERMOBEHÄLTER MIT AUSGUSSHAHN

Power: 230 V
Maße: 5 Liter Volumen
H 0,40 m Ø 0,40 m



THERMOBEHÄLTER MIT ZAPFHahn

Power: 230 V
Maße: 7 Liter Volumen
H 0,40 m B 0,40 m T 0,20 m



WÄRMEBEHÄLTER MIT ZAPFHahn

Power: 230 V
Maße: verschiedene Modelle



THERMOTRANSPORTBOX FAHRBAR

Maße: H 0,80 m B 0,80 m T 1,60 m



THERMOTRANSPORTBEHÄLTER

Power: 230 V
Maße: 20 Liter Volumen
H 0,35 m Ø 0,25 m



THERMOBOX BEHEIZT 1 GN 1/1

Power: 230 V
Maße: H 0,30 m B 0,65 m T 0,40 m

MAN MUSS AUCH MAL
GRILLEN
WENN MAN
KEINEN HUNGER HAT

FEUER
&
FLAMME
FÜR DEN GRILL



GRILLS



BBQ TISCHGRILL

Power: Holzkohle
Maße: H 0,25 m Ø 0,36 m



HOLZKOHLEGRILL AUF TISCH

Power: Holzkohle
Maße: 0,35 m B 0,65 m T 0,55 m



HOLZKOHLEGRILL FAHRBAR

Power: Holzkohle
Maße: H 1,00 m B 1,20 m T 0,80 m



HOLZKOHLEGRILL KLEIN

Power: Holzkohle
Maße: H 0,90 m B 0,80 m T 0,60 m



HOLZKOHLEGRILL MITTEL

Power: Holzkohle
Maße: H 1,0 m B 1,0 m T 1,0 m



HOLZKOHLEGRILL GROSS

Power: Holzkohle
Maße: H 1,0 m B 1,50 m T 1,0 m



ROLLSPIESSGRILL

Power: Holzkohle & 230 V
Maße: H 1,00 m B 1,40 m T 0,60 m



FISCHGRILL EDELSTAHL

Power: Holzkohle
Maße: H 1,80 m B 1,00 m T 0,90 m



SPANFERKELGRILL EDELSTAHL

Power: Holzkohle & 230 V
Maße: H 2,40 m B 1,70 m T 1,10 m



HÄHNCHENGRILL 12 SPIESSER

Power: Holzkohle & 230 V
Maße: H 2,10 m B 1,30 m B 0,60 m



SPANFERKELGRILL

Power: Holzkohle & 230 V
Maße: verschiedene Modelle



SACK HOLZKOHLE 15KG



GASGRILL AUFTISCH MIT PFANNE

Power: Propangas
Maße: verschiedene Modelle



GASGRILL AUFTISCH ROST ODER PFANNE

Power: Propangas
Maße: verschiedene Modelle



GASGRILL FAHRBAR ROST ODER PFANNE

Power: Propangas
Maße: verschiedene Modelle



GASGRILL MIT HAUBE

Power: Propangas
Maße: H 1,15 m B 1,55 m T 0,65 m



GASGRILL MIT ROST & PFANNE

Power: Propangas
Maße: H 1,0 m B 1,0 m T 1,0 m



GASGRILL MIT ROST

Power: 2 x Propangas
Maße: H 1,0 m B 1,30 m T 0,65 m



GYROSGRILL

Power: Propangas & 230 V
Maße: H 1,80 m B 1,00 m T 0,90 m



GASKASTEN EINFACH

Maße: verschiedene Modelle



GASKASTEN DOPPELT

Maße: verschiedene Modelle



HÄHNCHEN,- SPANFERKELGRILL 3 SPIESSER

Power: Propangas & 230 V
 Maße: H 0,70 m B 1,30 m T 0,45
 ca. 6 Hähnchen pro Spieß od. 1 x Ferkel 16kg



SPANFERKEL / FISCHGRILL

Power: Propangas & 230 V
 Maße: H 0,95 m B 1,05 m T 0,50 m
 ca. 11 Fische oder 1 Ferkel 16 kg



HÄHNCHENGRILL 8 SPIESSER MITDACH

Power: Propangas & 230 V
 Maße: H 1,80 m B 1,40 m T 0,70 m
 ca. 7 x Hähnchen pro Spieß



SPANFERKELGRILL 8 SPIESSER

Power: Propangas & 230 V
 Maße: verschiedene Modelle
 ca. 6 Hähnchen pro Spieß



HÄHNCHENGRILL 11 SPIESSER

Power: Propangas & 230 V
 Maße: H 1,80 m B 1,30 m T 0,60 m
 ca. 6 Hähnchen pro Spieß o. 1 Ferkel 16 kg



SPANFERKEL,- STECKERLFISCHGRILL

Power: Propangas & 230 V
 Maße: H 2,10 m B 1,20 m T 0,80 m
 ca. 6 Hähnchen pro Spieß



SPANFERKELGRILL MIT GLASTÜRE

Power: Propangas & 230 V
 Maße: H 1,00 m B 1,40 m T 0,60 m

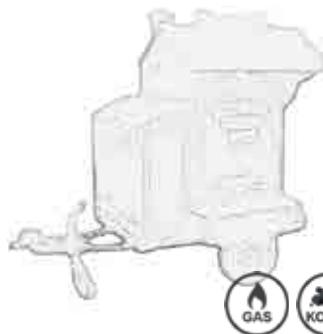

KARTOFFELOFFEN

Power: Gas oder Holzkohle
 ca. 150 Kartoffel + warmhalten



FLAMMBROTOFEN

Power: Gas oder Holzkohle
 Maße: H 1,50 m B 1,00 m T 1,20 m
 3 Einschübe



ELEKTROGRILL AUFTISCH KLEIN

Power: 230 V
Maße: Bratfläche 31 x 48 cm
verschiedene Modelle



ELEKTROGRILL AUFTISCH KLEIN

Power: 400 V, 16 A, CEE
Maße: Bratfläche 35 x 50 cm
verschiedene Modelle



ELEKTROGRILL AUFTISCH MITTEL

Power: 400 V, 16 A, CEE
Maße: Bratfläche 39 x 55 cm
verschiedene Modelle



ELEKTROGRILL AUFTISCH GROSS

Power: 400 V, 16 A, CEE
Maße: Bratfläche 66 x 48 cm
verschiedene Modelle



ELEKTROGRILL AUFTISCH KLEIN

Power: 400 V, 16 A, CEE
Maße: Bratfläche 36 x 50 cm
verschiedene Modelle



ELEKTROGRILL AUFTISCH GROSS

Power: 400 V, 16 A, CEE
Maße: Bratfläche
verschiedene Modelle



CERANGRILL AUFTISCH

Power: 400 V, 16 A, CEE
Maße: H 0,30 m B 0,65 m T 0,55 m



ELEKTROGRILL STANDGERÄT KLEIN

Power: 400 V, 16 A, CEE
Maße: verschiedene Modelle



ELEKTROGRILL STANDGERÄT GROSS

Power: 400 V, 16 A, CEE
Maße: verschiedene Modelle

**ELEKTROGRILL STANDGERÄT GRIDDLEPLATTE**

Power: 400 V, 16 A, CEE
Maße: verschiedene Modelle

**TEPPANYAKYGRILL "WAMSLER"**

Power: 2 x 32 A, CEE
Maße: H 1,00 m B 1,40 m T 0,60 m
6 Heizflächen

**FRESH & SMART MIT BOHNER FLACHGRILL**

Power: 400 V, 16 A, CEE
Maße: Bratfläche 66 x 48 cm
H 0,30m B 0,70m T 0,55m

**KLEMMGRILL EINFACH**

Power: 230 V
Maße: H 0,25 m B 0,31 m T 0,40 m

**KLEMMGRILL DOPPELT KLEIN**

Power: 400 V, 16 A, CEE
Maße: H 0,25 m B 0,31 m T 0,40 m

**KLEMMGRILL DOPPELT GROSS**

Power: 400 V, 16 A, CEE
Maße: H 0,25 m B 0,31 m T 0,40 m

**KLEMMGRILL CERAN**

Power: 400 V, 16 A, CEE
Maße: H 0,15 m B 0,65 m T 0,70 m

**GYROGRILL KLEIN**

Power: 230 V
Maße: H 0,15 m B 0,65 m T 0,70 m
ca. 20 kg Fleisch

**GYROGRILL GROSS**

Power: 400 V, 16 A, CEE
Maße: H 1,15 m B 0,95 m T 0,55 m
ca. 40 kg Fleisch

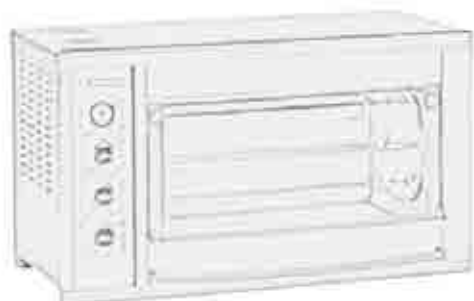

HÄHNCHEN / ROLLBRATENGRILL 3 SPIESSER

Power: 400 V, 16 A, CEE
 Maße: H 0,50 m B 1,00 m T 0,50 m
ca.3 Hähnchen pro Spieß



HÄHNCHENGRILL 4 SPIESSER

Power: 400 V, 32 A, CEE
 Maße: H 1,00 m B 1,10 m T 0,50 m
ca.3 Hähnchen pro Spieß

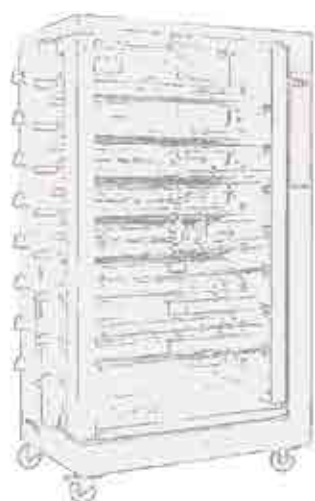

HÄHNCHENGRILL 15 SPIESSER

Power: 400 V, 63 A, CEE
 Maße: H 2,10 m B 1,20 m T 0,80 m
ca.6 Hähnchen pro Spieß



HÄHNCHENGRILL "PATERNOSTER" 15 KÖRBE

Power: 400 V, 63 A, CEE
 Maße: H 2,10 m B 1,20 m T 0,80 m
15 Körbe



HÄHNCHENGRILL "KSF" 15 SPIESSER

Power: Propangas & 230 V

Maße: H 2,10 m B 1,20 m T 0,80 m

5 - 6 Hähnchen pro Spieß

ECHT

COOL



KÜHL & GEFRIERGERÄTE



KÜHLSCHRANK GLASTÜRE

Power: 230 V
Maße: 360 L Volumen
H 1,95 m B 0,65 m T 0,65 m



KÜHLSCHRANK GROSS "STANDARD"

Power: 230 V
Maße: 360 L Volumen
H 1,80 m B 0,60 m T 0,65 m



KÜHLSCHRANK GROSS "PREMIUM"

Power: 230 V
Maße: 360 L Volumen
H 1,80 m B 0,60 m T 0,65 m



UMLUFTKÜHLSCHRANK

Power: 230 V
Maße: 700 L Volumen
H 2,10 m B 0,70 m T 0,80 m



UMLUFTKÜHLSCHRANK DOPPELTÜRIG

Power: 230 V
Maße: 1000 L Volumen
H 2,10 m B 0,70 m T 0,80 m



TELLERKÜHLER

Power: 230 V
Maße: H 2,10 m B 0,70 m T 0,80 m



FLASCHENKÜHLSCHRANK KLEIN PREMIUM

Power: 230 V
 Maße: 80 L Volumen
 H 0,85 m B 0,60 m T 0,55 m



FLASCHENKÜHLSCHRANK KLEIN STANDARD

Power: 230 V
 Maße: 80 L Volumen
 H 0,85 m B 0,60 m T 0,55 m



FLASCHENKÜHLSCHRANK KLEIN

Power: 230 V
 Maße: 170 L Volumen
 H 0,85 m B 0,60 m T 0,55 m



GEFRIERTRUHE

Power: 230 V
 Maße: 225 L Volumen
 H 0,85 m B 1,05 m T 0,65 m



GEFRIERTRUHE MIT GLASDECKEL

Power: 230 V
 Maße: 600 L Volumen
 H 0,80 m B 2,10 m T 0,80 m



PLUS / MINUS KÜHLTRUHE

Power: 230 V
 Maße: 300 L Volumen
 H 0,95 m B 0,95 m T 0,60 m



KÜHLVITRINE "TAPAS" 5 EINSÄTZE

Power: 230 V
Maße: verschiedene Modelle



KÜHLVITRINE "TAPAS" 6 EINSÄTZE

Power: 230 V
Maße: verschiedene Modelle



SALATBUFFET MIT MARMORFASSUNG 4 GN 1/1

Power: 230 V
Maße: verschiedene Modelle



SALATBUFFET QUADRATISCH 4 GN 1/1

Power: 230 V
Maße: H 0,80 m B 1,50 m T 1,50 m



SALADETTE

Power: 230 V
Maße: H 0,70 m B 1,00 m T 0,70 m



SALATBUFFET RECHTECKIG

Power: 230 V
Maße: H 1,50 m B 1,50 m T 0,80 m



KÜHLVITRINE KLEIN 1,00 - 1,25 M

Power: 230 V
Maße: verschiedene Modelle



KÜHLVITRINE GROSS 1,40 - 1,50 M

Power: 230 V
Maße: verschiedene Modelle



KÜHLVITRINE "DELI COOL"

Power: 230 V
Maße: H 0,70 m B 0,70 m T 0,60 m



KÜHLVITRINE "DELI COOL"

Power: 230 V
Maße: H 0,70 m B 0,90 m T 0,60 m



PANORAMAVITRINE 4-ECKIG

Power: 230 V
Maße: 5 Etagen



PANORAMAVITRINE 6-ECKIG

Power: 230 V
Maße: 6 Etagen



EISWÜRFELMASCHINE KLEIN

Power: 230 V & Festwasseranschluss
 Maße: ca. 25 kg in 24 h
 H 0,70 m B 0,50 m T 0,50 m



EISWÜRFELMASCHINE

Power: 230 V & Festwasseranschluss
 Maße: verschiedene Modelle



EISCRUSHER

Power: 230 V
 Maße: H 0,50 m B 0,25 m T 0,45 m



FROZEN MARGARITA-MASCHINE

Power: 230 V
 Maße: 12 L Volumen pro Tank
 verschiedene Modelle



DURCHLAUFKÜHLER 2-LÄUFIG

Power: 230 V
 Maße: verschiedene Modelle



FASSTHEKE FAHRBAR 1-LÄUFIG

Power: 230 V
 Maße: verschiedene Modelle



EIS TEPPANYAKI PLATTE

Power: 230V

Maße: H 0,50 m B 0,50 m T 0,50 m



SORBETIERE

Power: 230V

Maße: H 0,40 m B 0,60 m T 0,45 m



SPEISEEISTHEKE 4 EINSÄTZE

Power: 230 V

Maße: verschiedene Modelle



SPEISEEISTHEKE 9 EINSÄTZE

Power: 230 V

Maße: verschiedene Modelle



EISWAGEN

Power: 230 V

Maße: H 1,95 m B 0,65 m T 0,85 m

GLASKLAR

&

BLITZ

SAUBER



SPÜLTECHNIK

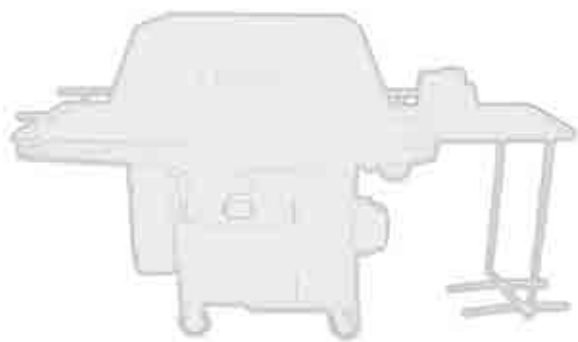

MASSKRUGSPÜLMASCHINE "GLR"

Power: 400 V, 16 A, CEE & Festwasseranschluß
Maße: H 1,30 m B 2,30 m T 1,30 m
ca. 1500 Krüge pro Stunde



MASSKRUGSPÜLMASCHINE "ZIPPEL Z II"

Power: 400 V, 32 A, CEE & Festwasseranschluß
Maße: H 1,30 m B 3,00 m T 0,90 m
ca. 2500 Krüge pro Stunde

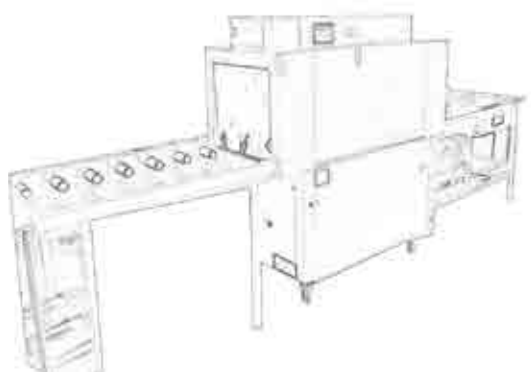

SPÜLMASCHINE KORBTRANSPORT "HOBART"

Power: 400 V, 32 A, CEE & Festwasseranschluß
Maße: H 2,20 m B 1,90 m T 0,80 m



SPÜLMASCHINE KORBTRANSPORT "DIHR"

Power: 400 V, 63 A, CEE & Festwasseranschluß
Maße: H 1,95 m B 3,70 m T 0,70 m



HANDWASCHBECKEN MIT SEIFEN & PAPIERSPENDER

Power: autark
Maße: H 0,85 m B 0,60 m T 0,50 m



HANDWASCHBECKEN MIT SCHMUTZWASSERAUSSGUSS

Power: 230 V für den Warmwasserboiler
Maße: H 1,60 m B 1,00 m T 0,60 m



EINBECKENSPÜLBECKEN

Maße: verschiedene Modelle



EINBECKENSPÜLBECKEN MIT ABLAGE

Maße: verschiedene Modelle



DOPPELSPÜLBECKEN

Maße: verschiedene Modelle



DOPPELSPÜLBECKEN MIT ABLAGE

Maße: verschiedene Modelle



FRONTLADER GASTROSPÜLMASCHINE

Power: 230 V
Maße: H 0,80 m B 0,60 m T 0,60 m



FRONTLADER GASTROSPÜLMASCHINE

Power: 400 V, 16 A, CEE
Maße: H 0,85 m B 0,60 m T 0,60 m



FRONTLADER GASTROSPÜLMASCHINE

Power: 400 V, 16 A, CEE
Maße: H 0,85 m B 0,60 m T 0,70 m



HAUBENSÜPÜLMASCHINE "GS 72"

Power: 400 V, 16 A, CEE
Maße: H 1,50 m B 0,75 m T 0,75 m



HAUBENSÜPÜLMASCHINE "WH 502" MIT ABFLAUFpumpe

Power: 400 V, 16 A, CEE
Maße: H 1,55 m B 0,75 m T 0,65 m



HAUBENSÜPÜLMASCHINE "WH PT-M"

Power: 400 V, 32 A, CEE
Maße: H 2,00 m B 0,75 m T 0,75 m



ZULAUFtisch MIT PENDELBRAUSE

Maße: H 0,95 m B 1,30 m T 0,75 m



HAUBENSÜPÜLMASCHINE MIT ZU-, & ABFLAUFtisch



ABFLAUFtisch

Maße: H 0,85 m B 1,00 m T 0,80 m



SPÜLBOY

Maße: verschiedene Modelle



SPÜLBOY FÜR KRÜGE

Maße: verschiedene Modelle



SPÜLBÜRSTEN

Maße: verschiedene Modelle



BOILER

Power: 230 V
Maße: verschiedene Modelle



DURCHLAUFERHITZER

Power: 230 V
Maße: verschiedene Modelle



PENDELBRAUSE

Maße: verschiedene Modelle



SPÜLKORB MIT FINGER



SPÜLKORB



GESCHIRRBOXEN

NICHT DIE
HAUPTSACHE
ABER
OHNE UNS
GEHT NICHTS



GERÄTEZUBEHÖR



EDELSTAHTÖPFE

Maße: verschiedene Modelle mit/ohne Deckel



KASSEROLLEN

Maße: verschiedene Modelle

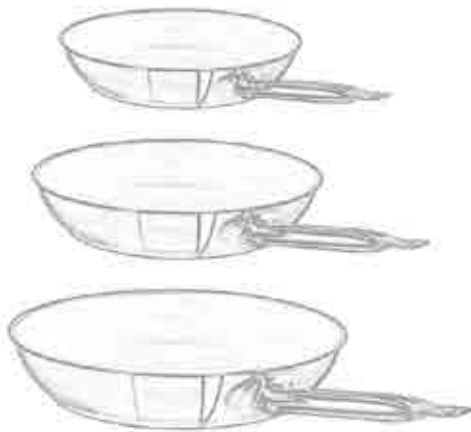

EDELSTAHPFANNEN

Maße: verschiedene Modelle



EDELSTAHSCHÜSSELN

Maße: verschiedene Modelle



GN BEHÄLTER

Maße: verschiedene Modelle mit/ohne Deckel



GN BLECHE

Maße: verschiedene Modelle



GN LOCHBLECHE

Maße: verschiedene Modelle



BREZENBACKBLECHE 1/1 GN UND BÄCKERMASS

Maße: B 0,53 m T 0,32 m
B 0,60 m T 0,40 m



KÜCHENHELFER

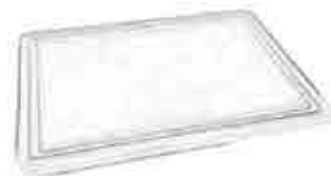

SCHNEIDEBRETTER

Maße: verschiedene Modelle

Vielfalt
und
Frische



ASIEN



INDUKTIONSKOCHFELD

Power: 230 V
Maße: H 0,35 m B 0,40 m T 0,45 m



INDUKTIONSWOK

Power: 230 V
Maße: H 0,20 m B 0,40 m T 0,50 m



WOKEINSATZ FÜR INDUKTIONSKOCHFELD

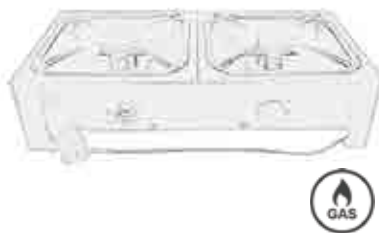

TISCHKOCHER GAS DOPPELT

Power: Propangas
Maße: H 0,2 m B 0,5 m T 0,8 m

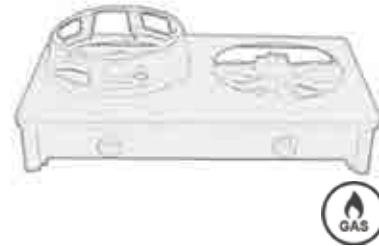

TISCHKOCHER GAS DOPPELT WOK

Power: Propangas
Maße: verschiedene Modelle



INDUKTIONSWOKPFANNE



INDUKTIONSWOKPFANNE FLACHER BODEN



RIESENWOK FÜR HOCKERKOCHER



DIM SUM KÖRBCHEN

Maße: verschiedene Modelle



REISKOCHER_GROSS

Power: 230 V

Maße: verschiedene Modelle



KÜHLVITRINE "SUSHI" 5 EINSÄTZE

Power: 230 V

Maße: verschiedene Modelle



KÜHLVITRINE "SUSHI" 6 EINSÄTZE

Power: 230 V

Maße: verschiedene Modelle



TEPPANYAKIGRILL "WAMSLER"

Power: 2 x 400 V, 32 A, CEE

Maße: H 0,95 m B 1,70 m T 1,30 m



EIS TEPPANYAKI PLATTE

Power: 230 V

Maße: H 0,50 m B 0,50 m T 0,50 m

Genuss

ist jede

Sünde

wert



AMERIKA



ELEKTROGRILL AUFTISCH KLEIN

Power: 230 V
 Maße: Bratfläche 31 x 48 cm
 H 0,95m B 0,40m T 0,65m



ELEKTROGRILL AUFTISCH KLEIN

Power: 400 V, 16 A, CEE
 Maße: Bratfläche 35 x 50 cm
 H 0,95m B 0,40m T 0,65m



ELEKTROGRILL AUFTISCH MITTEL

Power: 400 V, 16 A, CEE
 Maße: Bratfläche 39 x 55 cm
 H 0,30m B 0,70m T 0,55m



ELEKTROGRILL AUFTISCH GROSS

Power: 230 V
 Maße: Bratfläche 31 x 48 cm
 H 0,95m B 0,40m T 0,65m



ELEKTROGRILL AUFTISCH KLEIN

Power: 400 V, 16 A, CEE
 Maße: Bratfläche 36 x 50 cm
 verschiedene Modelle



CERANGRILL AUFTISCH

Power: 400 V, 16 A, CEE
 Maße: H 0,30 m B 0,65 m T 0,55 m



BBQ TISCHGRILL

Power: Holzkohle
 Maße: H 0,25 m Ø 0,36 m



KLEMMGRILL EINFACH

Power: 230 V
 Maße: H 0,25 m B 0,31 m T 0,40 m



KLEMMGRILL DOPPELT

Power: 400 V, 16 A, CEE
 Maße: H 0,25 m B 0,31 m T 0,40 m



HOLZKOHLEGRILL KLEIN

Power: Holzkohle
Maße: H 0,90 m B 0,80 m T 0,60 m



HOLZKOHLEGRILL GROSS

Power: Holzkohle
Maße: H 1,00 m B 1,50 m T 1,00 m



GASGRILL FAHRBAR ROST ODER PFANNE

Power: Propangas
Maße: verschiedene Modelle



GASGRILL MIT ROST

Power: 2 x Propangas
Maße: H 1,0 m B 1,3 m T 0,65 m



GASGRILL MIT HAUBE

Power: Propangas
Maße: H 1,15 m B 1,55 m T 0,65 m



SMOKER

Power: Holzkohle
Maße: verschiedene Modelle



HOT DOG-WÜRSTCHENWÄRMER

Power: 230 V
Maße: verschiedene Modelle



HOT DOG-ROLLGRILL

Power: 230 V
Maße: verschiedene Modelle



HOT DOG-BROTSPIESS

Power: 230 V
Maße: verschiedene Modelle



WÜRSTCHENWÄRMER 2 BECKEN

Power: 230 V
Maße: 5 Liter Volumen pro Becken
H 0,30 m B 0,75 m T 0,30 m



WARMHALTEGERÄT FÜR POMMES

Power: 230 V
Maße: H 0,60 m B 1,10 m T 0,80 m



DOPPELFRITEUSE KLEIN

Power: 2 x 230 V
Maße: 5 - 8 Liter Volumen pro Becken, versch. Modelle

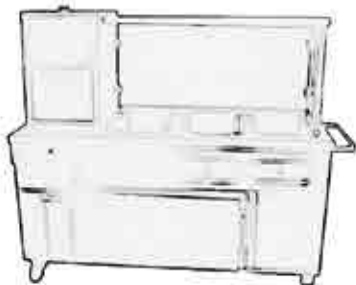

HOT DOG STAND

Power: 400 V, 16 A, CEE
Maße: H 1,45 m B 1,60 m T 0,70 m



HOT DOG WAGEN

Power: Propangas o. 230 V
Maße: H 1,60 m B 1,20 m T 1,80m



ZUCKERWATTEMASCHINE

Power: 230 V
Maße: verschiedene Modelle

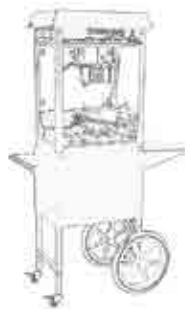

ZUCKERWATTEMASCHINE MIT WAGEN

Power: 230 V
Maße: H 1,00 m B 0,80 m T 0,80 m



MINIDONUTMASCHINE

Power: 230 V
Maße: H 0,40 m B 0,90 m T 0,60 m



POPCORNMASCHINE KLEIN

Power: 230 V
Maße: verschiedene Modelle
15 L in 1 Std.



POPCORNMASCHINE KLEIN

Power: 230 V
Maße: verschiedene Modelle
15 L in 1 Std.



POPCORNMASCHINE MIT WAGEN

Power: 230 V
Maße: verschiedene Modelle
15 L in 1 Std.



FROZEN MARGARITA MASCHINE

Power: 230 V
Maße: H 0,70 m B 0,40 m T 0,45 m
12 L Volumen pro Behälter



ORANGENPRESSE "ZUMEX"

Power: 230 V
Maße: H 1,70 m B 0,70 m T 0,70 m

*ESSEN IST EIN
BEDÜRFNIS,
GENIEßEN
EINE
KUNST*



MEDITERRAN - VEGGI



PASTAKOCHER TISCHGERÄT INKL. 1 EINSATZ

Power: 400 V, 16 A, CEE
Maße: verschiedene Modelle

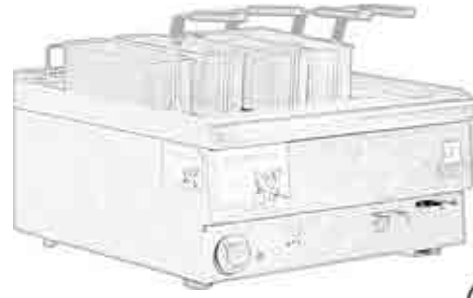

PASTAKOCHER TISCHGERÄT INKL. 4 EINSÄTZE

Power: 400 V, 16 A, CEE
Maße: verschiedene Modelle

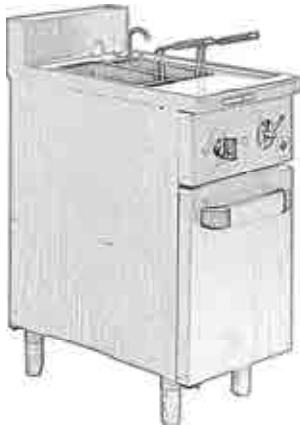

PASTAKOCHER STANDGERÄT INKL. 2 EINSÄTZE

Power: 400 V, 16 A, CEE
Maße: verschiedene Modelle



PASTAKOCHER STANDGERÄT INKL. 4 EINSÄTZE

Power: 400 V, 16 A, CEE
Maße: H 0,95 m B 0,75 m T 0,35 m



PASTAKOCHER STANDGERÄT INKL. 2 EINSÄTZE

Power: 400 V, 16 A, CEE
Maße: verschiedene Modelle



AUFSCHNITTMASCHINE BERKEL

Power: 230 V
Maße: H 1,50 m B 1,50 m T 0,80 m



PIZZAOFEN KLEIN 1 - STÖCKIG

Power: 230 V
Maße: H 0,35 m B 0,75 m T 0,75 m



PIZZAOFEN MITTEL 1 - STÖCKIG

Power: 400 V, 16 A, CEE
Maße: H 0,45 m B 0,95 m T 0,85 m



PIZZAOFEN GROSS 2 - STÖCKIG

Power: 400 V, 16 A, CEE
Maße: verschiedene Modelle

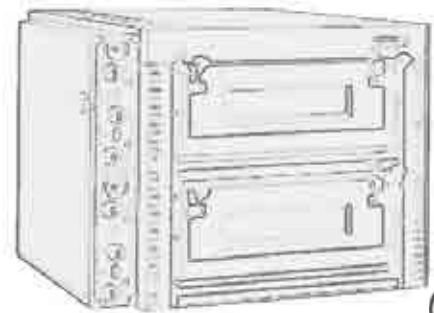

PIZZAOFEN GROSS 2 - STÖCKIG

Power: 400 V, 16 A, CEE
Maße: verschiedene Modelle



PIZZADURCHLAUFOFEN

Power: 400 V, 16A CEE
Maße: H 0,40 m B 1,30 m T 0,80 m



PIZZA ZUBEHÖR

Maße: verschiedene Modelle

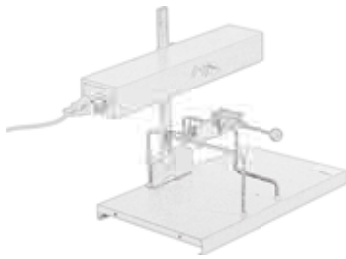

RACLETTEOFEN

Power: 230 V
Maße: verschiedene Modelle



RACLETTEOFEN FÜR 3 LAIBE

Power: 230 V
Maße: verschiedene Modelle



MARONIOFEN

Power: verschiedene Modelle
Maße: H 0,90 m Ø 0,60 m



SALADETTE

Power: 230 V
Maße: H 0,70 m B 1,00 m T 0,70 m



KARTOFFELOFFEN

Power: 230 V
Maße: H 0,95 m B 0,60 m T 0,75 m
ca. 150 Kartoffel + warmhalten



FLAMMBROTOFEN

Power: Gas oder Holzkohle
Maße: H 1,50 m B 1,00 m T 1,20 m



SIEBTRÄGER ESPRESSOMASCHINE

Maße: verschiedene Modelle



ESPRESSO, - KAFFEEBOHNENMÜHLE

Power: 230 V

Maße: verschiedene Modelle



SAHNEBEREITER

Power: 230 V

Maße: H 0,65 m B 0,35 m T 0,65 m



DAMPFNUDELWÄRMER

Power: 230V

Maße: H 0,60 m B 0,35 m T 0,50 m



WAFFELEISEN

Power: Gas o. 16 A, CEE

Maße: verschiedene Modelle



CREPESGERÄT

Power: Gas o. 16 A, CEE

Maße: verschiedene Modelle



SORBETIERE

Power: 230 V

Maße: H 0,40 m B 0,60 m T 0,45 m



EISTHEKE

Power: 230 V

Maße: verschiedene Modelle

WIR MÜSSEN

UNS NICHT

FINDEN,

WIR SIND IMMER

AN DER

BAR



**BAR, BIERZELT,
HEURIGEN & GARTENPARTY**





ENTSAFTER

Power: 230 V

Maße: verschiedene Modelle



ZITRUSPRESSE

Power: 230 V

Maße: verschiedene Modelle



STANDMIXER

Power: 230 V

Maße: verschiedene Modelle



FROZEN MARGARITA MASCHINE

Power: 230 V

Maße: 12 L Volumen pro Behälter
H 0,70 m B 0,40 m T 0,45 m



HÄHNCHENGRILL 15 KÖRBE

Power: 400 V, 63 A, CEE
 Maße: H 2,10 m B 1,20 m T 0,80 m
 15 Körbe



HÄHNCHENGRILL 15 SPIESSER

Power: 400 V, 63 A, CEE
 Maße: H 2,10 m B 1,20 m T 0,80 m
 ca. 6 Hähnchen pro Spieß



HÄHNCHENGRILL 4 SPIESSE

Power: 400 V, 32 A, CEE
 Maße: H 1,00 m B 1,10 m T 0,50 m
 ca. 3 Hähnchen pro Spieß



HÄHNCHENGRILL 15 SPIESSE

Power: 400 V, 63 A, CEE
 Maße: H 2,10 m B 1,20 m T 0,80 m
 ca. 6 Hähnchen pro Spieß



HÄHNCHENGRILL 8 SPIESSE

Power: Gas & 230 V
 Maße: H 1,80 m B 1,40 m T 0,70 m
 ca. 7 x Hähnchen pro Spieß



SPANFERKELGRILL GROSS

Power: Holzkohle & 230 V
 Maße: verschiedene Modelle

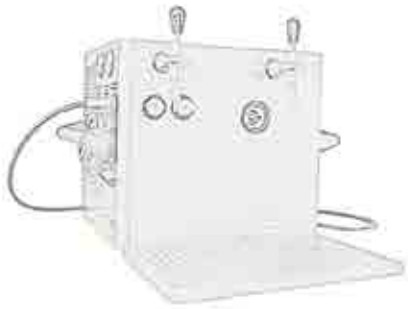

BIERDURCHLAUFKÜHLER

Power: 230 V

Maße: verschiedene Modelle



FASSTHEKE FAHRBAR 1-LÄUFIG

Power: 230 V

Maße: verschiedene Modelle

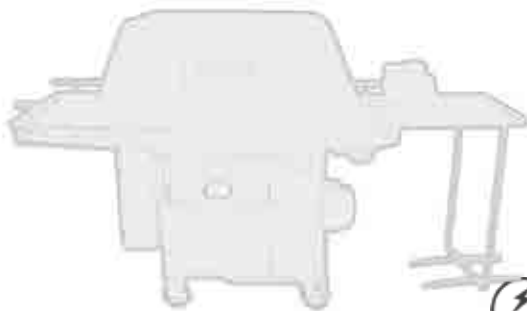

MASSKRUGSPÜLMASCHINE

Power: 230 V

Maße: verschiedene Modelle



AUFSCHNITTMASCHINE

Power: 230 V

Maße: verschiedene Modelle

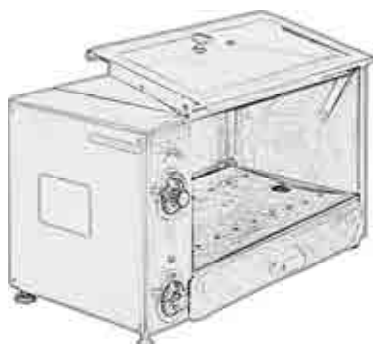

LEBERKÄSWARMHALTEOFEN

Power: 230 V

Maße: H 0,50 m B 0,60 m T 0,30 m



CURRYWURST - SCHNEIDER

Power: 230 V

Maße: verschiedene Modelle

ALLES

WATT

IHR

VOLT



**STROM, ZU,- ABWASSER,
HEIZUNG & KÜHLEN**





VERLÄNGERUNGSKABELSTARKSTROM



3FACH STECKDOSE



ELEKTROVERTEILUNG 32 A CEE



ADAPTER VON 32 A CEE AUF 16 A

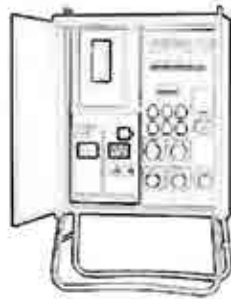

BAUSTROMVERTEILER



MEHRFACH - GASVERTEILER SET



ELEKTROVERTEILUNG 63 A CEE



ELEKTROVERTEILUNG 16 A CEE



STROMVERTEILER PCE VON 16



ABWASSERHEBEANLAGE

Power: 230V

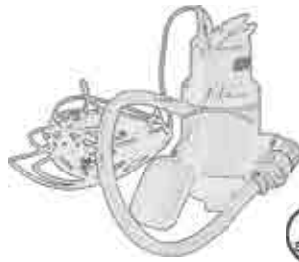

SCHMUTZWASSERPUMPE

Power: 230V



HAUSWASSERWERK DRUCKPUMPE

Maße: verschiedene Modelle



FETTABSCHIEDER KLEIN

Maße: verschiedene Modelle



FETTABSCHIEDER MITTEL

Maße: verschiedene Modelle



FETTABSCHIEDER GROSS

Maße: verschiedene Modelle



FETTABSCHIEDER EDELSTAHL

Maße: verschiedene Modelle

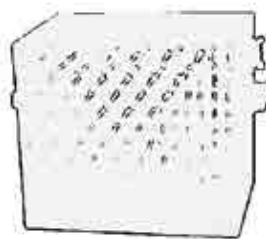

SCHMUTZABWASSERHEBEPUMPE

Maße: verschiedene Modelle



DIVERSE ABWASSERLEITUNGEN



TRINKWASSERTANK 800 L



TRINKWASSERTANK 1000 L



TRINKWASSERSCHLÄUCHE



TRINKWASSERVERTEILER



GEKA-KLAUENKUPPLUNG 3/4"



GEKA-KLAUENKUPPLUNG SCHLAUCH



GEKA-KLAUENKUPPLUNG Y-VERTEILER



GEKA-KLAUENKUPPLUNG SCHLAUCHSTÜCK



GEKA-KLAUENKUPPLUNG SCHLAUCH





PARTYSTRAHLER

Power: Propangas
Maße: H 2,20 m Ø 0,75 m



PARTYSTRAHLER FEUER PYRAMIDE

Power: Propangas
Maße: H 2,20 m B 0,65 m T 0,65 m



HEIZSTRAHLER

Power: 230 V
Maße: H 2,00 m Ø 0,40 m



FEUERKORB

Power: Brennholz
Maße: verschiedene Modelle



FEUERSCHALE

Power: Brennholz
Maße: verschiedene Modelle



FEUERTONNE

Power: Brennholz
Maße: H 1,00 m Ø 0,60 m



WARMLUFTGEBLÄSE KLEIN

Power: 230 V
Maße: verschiedene Modelle



WARMLUFTGEBLÄSE GROSS

Power: 400 V, 16 A, CEE
Maße: verschiedene Modelle



HEIZSTRAHLER KATALYTAUFSATZ

Power: Propangas
Maße: verschiedene Modelle

**IT'S
ALL
ABOUT
MOVING
FORWARD**

wir verleihen
alles für Ihr event

ankl24
eventausstatter

www.frankl24.com

TRANSPORTLOGISTIK





HORDENGESTELLWAGEN

7 GN 1/1
Maße: H 0,90 m B 0,36 m T 0,60 m



HORDENGESTELLWAGEN Z

36 GN 1/1
Maße: H 1,65 m B 0,65 m T 0,60 m

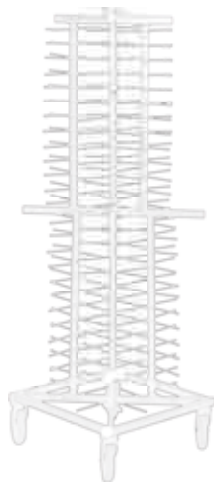

TELLERSPINNE GROSS

Maße: H 1,85 m B 0,65 m T 0,65 m



TELLERSPINNE

Maße: H 1,85 m B 0,60 m T 0,60 m

AGB

Allgemeine Geschäftsbedingungen Party-Verleih Frankl GmbH

1. Allgemeines

Diese Allgemeinen Geschäftsbedingungen (AGB) sind ausschließliche Geschäftsgrundlage der Lieferungen und Leistungen der Party-Verleih Frankl GmbH (im weiteren Vermieter). Entgegenstehenden AGB wird widersprochen. Mündliche Abreden und Zusicherungen bedürfen zu ihrer Wirksamkeit der schriftlichen Bestätigung.

2. Zustandekommen des Mietvertrages

Ein Mietvertrag über einen Gegenstand kommt zustande, wenn der Mieter das unverbindliche Angebot des Vermieters angenommen hat und dieser die Annahme schriftlich rückbestätigt hat. Eine Rückbestätigung ist auch durch Lieferung / Zurverfügungstellung der Gegenstände möglich.

3. Mietobjekt

Die Mietobjekte sind dem Online-Katalog, dem Bestellformular oder der Auftragsbestätigung zu entnehmen. Die nach bestem Wissen und Gewissen vorgenommenen Beschreibungen sind Zirka-Werte und -Maße und ebenso wie die Farben und Formen keine zugesicherten Eigenschaften. Es gelten die Auftrags- und Bestellnummern sowie die Objektbezeichnungen des Vermieters.

Die zur Miete bestimmten Objekte sind gebraucht.

4. Mietpreis

Der Mietpreis der Mietobjekte bemisst sich grundsätzlich nach unserer Preisliste in der jeweils gültigen Fassung sowie oder nach individuellem Angebot. Er wird pro angefangenen Kalendertag berechnet. Ist zusätzlich zum Mietpreis ein Preis für die Reinigung ausgewiesen, so ist dieser unabhängig von Verschmutzung zu begleichen. Die Preise verstehen sich grundsätzlich inklusive der gesetzlichen Mehrwertsteuer, sofern nicht anders ausgewiesen. Die Mietpreise verstehen sich ab dem jeweiligen Lager des Vermieters ohne Transport. Der Mieter erkennt die Geltung der Preise und Konditionen an.

5. Mietzeit

Als vertragliche Mietzeit gilt ausschließlich die vereinbarte Zeit; im Zweifel ein Tag (1 Tag = 1 Mieteinheit). Die Mietzeit beginnt mit Abholung und endet mit Rückgabe. Ist Lieferung vereinbart so gilt der Beginn des Anlieferungsverkehrs und das Ende des Abholverkehrs.

6. Verlängerung der Mietzeit

Für eine Verlängerung der vereinbarten Mietzeit, ist die schriftliche Zustimmung des Vermieters erforderlich, die mindestens 12 Stunden vor Ablauf der Mietzeit auf Kosten des Mieters eingeholt werden muss. Der Vermieter hat nach Ablauf der vertraglichen Mietzeit das Recht, die zusätzlich angefallene Zeit entsprechend der Preisliste abzurechnen; die Geltendmachung weiteren Schadens wird vorbehalten. Einer Verlängerung durch Vorenthaltung / Inbesitzhaltung wird ausdrücklich widersprochen.

7. Nachbestellung

Bei Nachbestellung des Mieters kann der Vermieter solange nicht für die vollständige Ausführung des Nachbestellungsauftrages haftbar gemacht werden, bis dem Mieter eine schriftliche Bestätigung zugegangen ist.

8. Rückgabe, Bruch und Verlust

Der Mieter trägt die Verantwortung für gemietete Gegenstände von der Übernahme bis zur Rückgabe. Die Rückgabe kann grundsätzlich nur zu den üblichen Geschäftszeiten (Montag bis Freitag von 08:00 bis 18:00 Uhr und Samstag von 08:00 bis 13:00 Uhr) erfolgen. Der Mieter verpflichtet sich, die gemieteten Gegenstände pfleglich zu behandeln und in einwandfreiem Zustand zurückzubringen. Die Abnahmekontrolle ist erst im Lager möglich. Die Rücknahme erfolgt daher grundsätzlich unter dem Vorbehalt der Vollständigkeit und Unversehrtheit. Exakte Bruch- und Verlustmengen können erst nach vollständigem Reinigungsprozess ermittelt werden. Nach Wahl des Vermieters kann das Mietobjekt ersetzt oder repariert werden, je nachdem was für den Mieter gemessen am Wiederbeschaffungswert laut Preisliste günstiger ist. Des Weiteren trägt der Mieter bei Verlust oder Beschädigung die Mietkosten bis zur Wiederbeschaffung bzw. Reparatur.

9. Reinigung

Für die zusätzlich zum Mietpreis zu vergütende Reinigung hat der Mieter das Mietobjekt ordentlich und sortiert, fertig zur maschinellen Reinigung vorzubereiten. Die Reinigung von Geräten und anderen Verleihgegenständen berechnen wir gemäß den vereinbarten Preisen oder nach Aufwand. Die Reinigung erfolgt unverzüglich nach Rückgabe. Bei übermäßiger Verschmutzung sowie bei Schäden wird ein Mehraufwand separat abgerechnet.

10. Stornierung

Die Stornierung des Auftrags ist bis zu 14 Tagen vor der vereinbarten Übergabe bzw. Liefertermin für den Mieter kostenfrei möglich. Bei einer Stornierung bis zu 7 Tagen vor dem vereinbarten Liefertermin fallen 50% des vereinbarten Mietpreises, danach der volle Mietpreis an. Von den anfallenden Gebühren werden Einkünfte aus anderweitiger Vermietung und ersparte Aufwendungen abgezogen.

AGB

Allgemeine Geschäftsbedingungen Party–Verleih Frankl GmbH

11. Gefahrübergang

Ort des Gefahr- und Haftungsübergangs ist stets am jeweiligen Lager des Vermieters. Der Vermieter garantiert, dass die Ware Übernahme. Der Mieter muss den Vermieter unverzüglich informieren, wenn das Mietobjekt bei der Anlieferung / Übergabe nicht vollständig, beschädigt oder verloren gegangen ist oder gestohlen wurde.

12. Transport

Ist Abholung vereinbart, so hat der Mieter das Material in einem geschlossenen Transporter, ordnungsgemäß gesichert, auf eigene Gefahr und Kosten zu transportieren. Ist Lieferung vereinbart, so erfolgt diese auf Kosten und Risiko des Mieters. Der Vermieter liefert das Mietobjekt frei Bordsteinkante an und holt es zum vereinbarten Zeitpunkt frachtsicher verpackt dort wieder ab; im Zweifel am nächsten Tag ab 08:00 Uhr. Liefertermine sind unverbindlich und beinhalten stets eine Karenzzeit von 3 Stunden, sofern sie nicht als Fixtermine einvernehmlich vereinbart und schriftlich durch den Vermieter bestätigt wurden. Die Transportkosten beinhalten nicht den Auf- und Abbau sowie das Verpacken und Einsammeln der gemieteten Gegenstände. Diese Leistungen übernehmen wir nach vorheriger Buchung gerne gegen gesonderte Berechnung. Bitte erkundigen Sie sich nach unserem Angebot. Der Mieter stellt sicher, dass dem Vermieter zum vereinbarten Lieferzeitpunkt ein freier und geeigneter Zugangsweg (geeignet für LKW bis 7,5 Tonnen) zur Verfügung steht, es sei denn ein anderes Fahrzeug wurde vereinbart. Treten bei An- und Abfahrt Schäden am Gelände und / oder an Gebäuden auf, die auf Ungeeignetheit des Zugangsweges zurückzuführen sind, haftet der Mieter. Für Verzögerungen bei Anlieferung und Abholung, die durch den Mieter verursacht wurden, haftet der Mieter insoweit, als jede angefangene Viertelstunde Wartezeit pro LKW mit € 10,00 und pro Mann mit € 10,00 zu Lasten des Mieters abgerechnet werden.

13. Unmöglichkeit

Ist die Vertragserfüllung für den Vermieter unmöglich, kann der Mieter erst dann kündigen, nachdem dem Vermieter schriftlich eine angemessene Frist zur Nacherfüllung gesetzt worden ist.

14. Mängelhaftung

Eine Haftung des Vermieters ist grundsätzlich ausgeschlossen im Falle von anfänglich vorhandenen Mängeln der Mietsache, wenn die Mängel trotz Erkennbarkeit nicht angezeigt worden sind oder im Falle von höherer Gewalt (technische Störungen, behördliche Anordnung, Naturkatastrophen). Sind Mängel vorhanden, steht dem Mieter ein Zurückbehaltungsrecht nicht zu, solange dies nicht in angemessenem Verhältnis zu den Mängeln und den voraussichtlichen Kosten der Mängelbeseitigung steht. Die Verschuldens unabhängige Haftung ist ausgeschlossen. Im Falle von Vorsatz und grober Fahrlässigkeit, auch seiner Vertreter und Erfüllungsgehilfen, haftet der Vermieter gemäß den gesetzlichen Bestimmungen. Die Haftung wird mit Ausnahme der Haftung für Vorsatz auf den vorhersehbaren, typischerweise eintretenden Schaden begrenzt. Die Haftung wegen Verletzung des Lebens, des Körpers oder der Gesundheit bleibt unberührt. Der Mieter stellt den Verwender von Ansprüchen Dritter wegen Schäden aus der Benutzung des Mietobjekts frei. Die Verjährungsfrist für diese Ansprüche beträgt 12 Monate ab gesetzlichem Verjährungsbeginn.

15. Gesamthaftung

Eine über die in 14. genannte Haftung ist ausgeschlossen. Dies gilt insbesondere für Haftung aus Verschulden bei Vertragsabschluss, wegen sonstiger Pflichtverletzungen oder wegen deliktischer Ansprüche auf Ersatz von Sachschäden.

16. Pflichten des Mieters

Der Mieter ist verpflichtet die überlassenen Sachen pfleglich, sachgerecht und ordnungsgemäß zu behandeln und sie gegebenenfalls bewachen zu lassen. Er hat erteilte Gebrauchs-, Wartungs- und Pflegehinweise einzuhalten. Er hat sich bei Anlieferung oder Abholung vom ordnungsgemäßen Zustand der Mietsache zu überzeugen und Mängel unverzüglich beim Vermieter anzuzeigen. Eine Überlassung an Dritte oder Verbringung außerhalb der Bundesrepublik Deutschland ist untersagt. Der Mieter hat die Sache frei von Rechten Dritter zu halten.

17. Zahlungsbedingungen

Der Mietpreis ist bei Übernahme der Ware sofort fällig. Bei Zahlungsverzug werden Zinsen in Höhe von 1% auf die Forderungen des Vermieters je angebrochenem Monat berechnet. Bei Zahlung in ausländischer Währung gehen ein etwaiger Kursverlust und Einlösungsspesen zu Lasten des Mieters. Eine Aufrechnung mit Gegenforderungen des Mieters ist nur mit unstreitigen oder titulierten Ansprüchen möglich.

18. Geltendes Recht / Gerichtsstand

Es gilt das Recht der Bundesrepublik Deutschland unter Ausschluss des CISG. Erfüllungsort ist der jeweilige Sitz des Vermieters. Ausschließlicher Gerichtsstand ist München, sofern der Käufer Kaufmann ist oder keinen Wohnsitz in Deutschland unterhält; dies gilt auch für Scheck- und Wechselklagen. Der Mieter ist mit einer Speicherung seiner Daten im Sinne des BDSG für geschäftliche Zwecke einverstanden.

Sauerlach, im August 2021